

J2-2-BASE

User Manual V1.0 2022.06

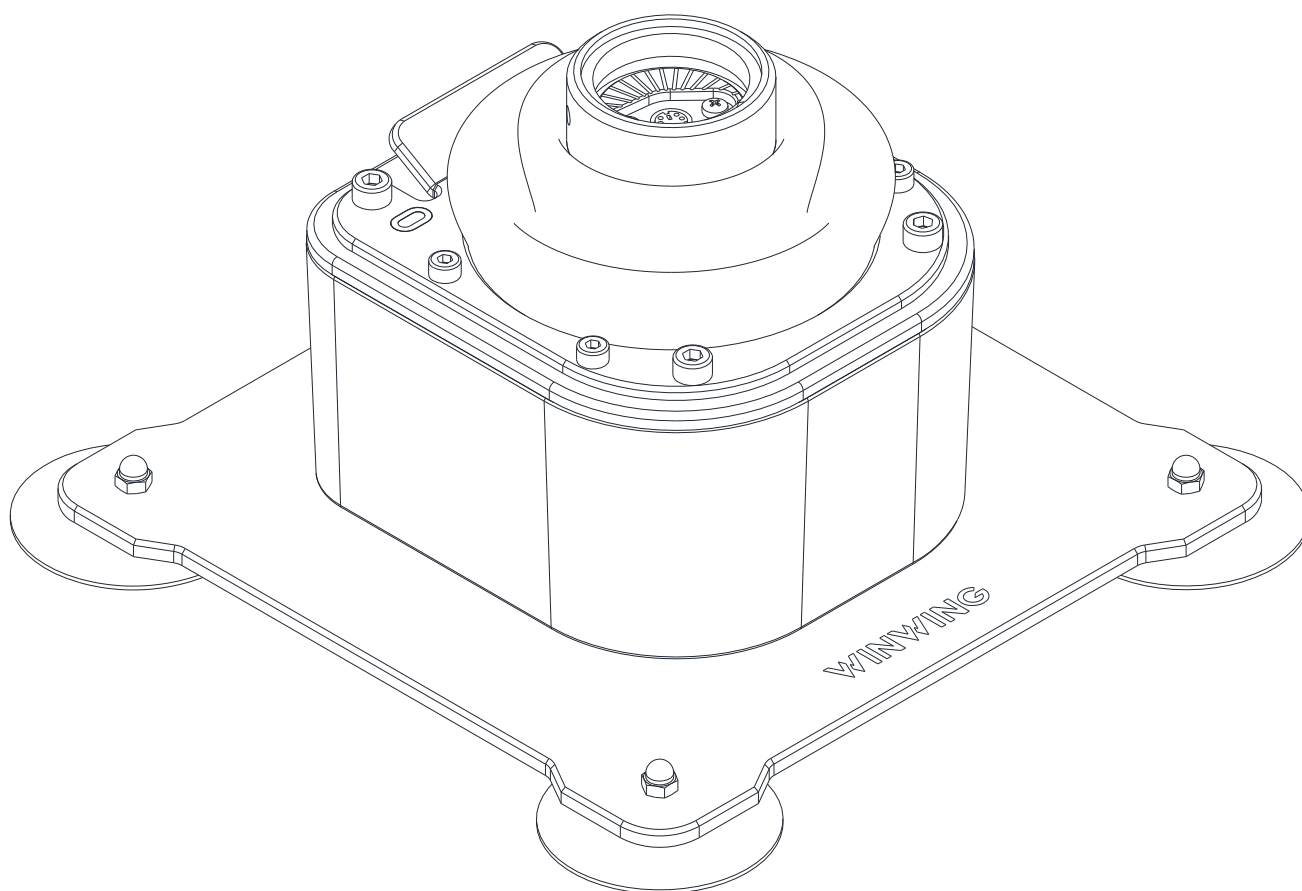

Contents

Contents in the box	3
1 Reference Data	2
1.1 Performance	2
1.2 Applicable Model	3
1.3 Appearance and dimension	4
1.4 Installation dimension	4
2 Functions.....	5
2.1 Mechanical and additional functions.....	5
3 Parts installation	7
3.1 Suction cups installation	7
3.2 Cams installation.....	7
3.3 Resistance model	7
3.4 Movable multiple force sensor mode.....	7
4 Assembly methods	8
4.1 Devices connection	8
4.2 Mounting installation.....	9

Contents in the box

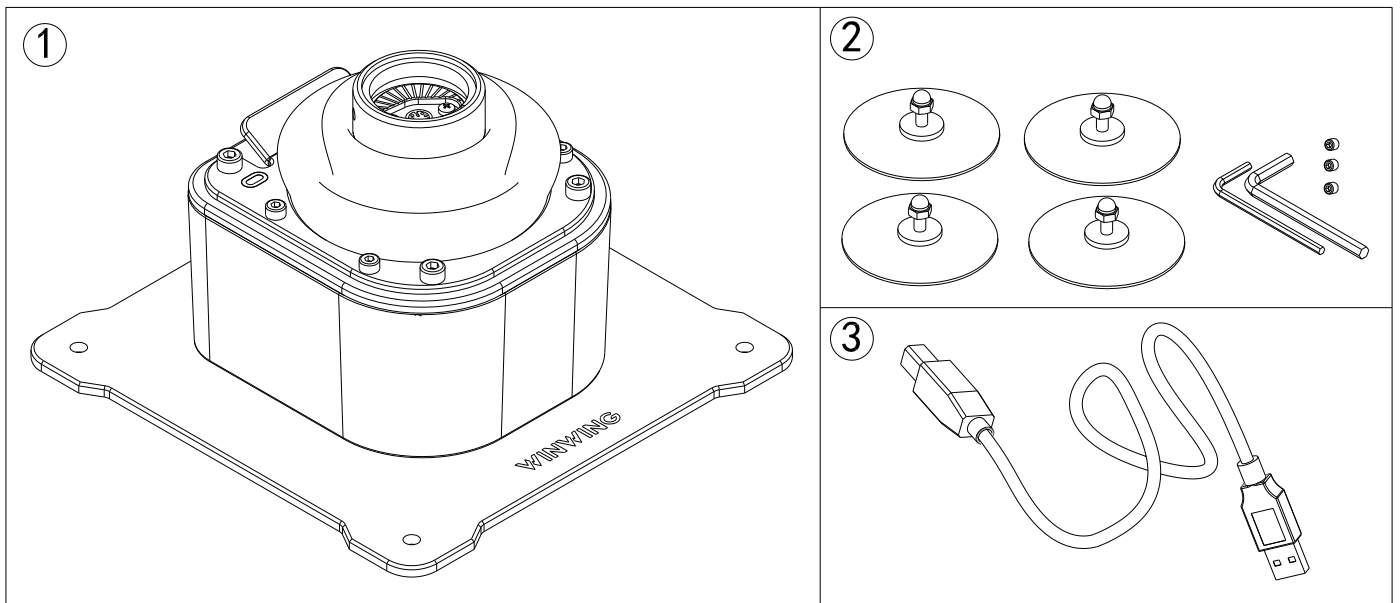

- ① J2-2-BASE (1#)
- ② Accessories Bag (2#)
- ③ USB cable (3#)

1
1
1

1 Reference Data

1.1 Performance

- ① Pitch roll, the rotation angle of Roll: $\pm 17^\circ$;
- ② Expandable force feedback* ;
- ③ Resistance model* ;
- ④ Movable multiple force sensor mode*.

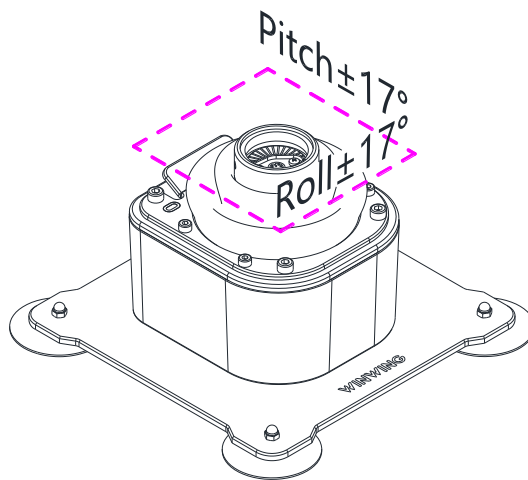

1.2 Applicable Model

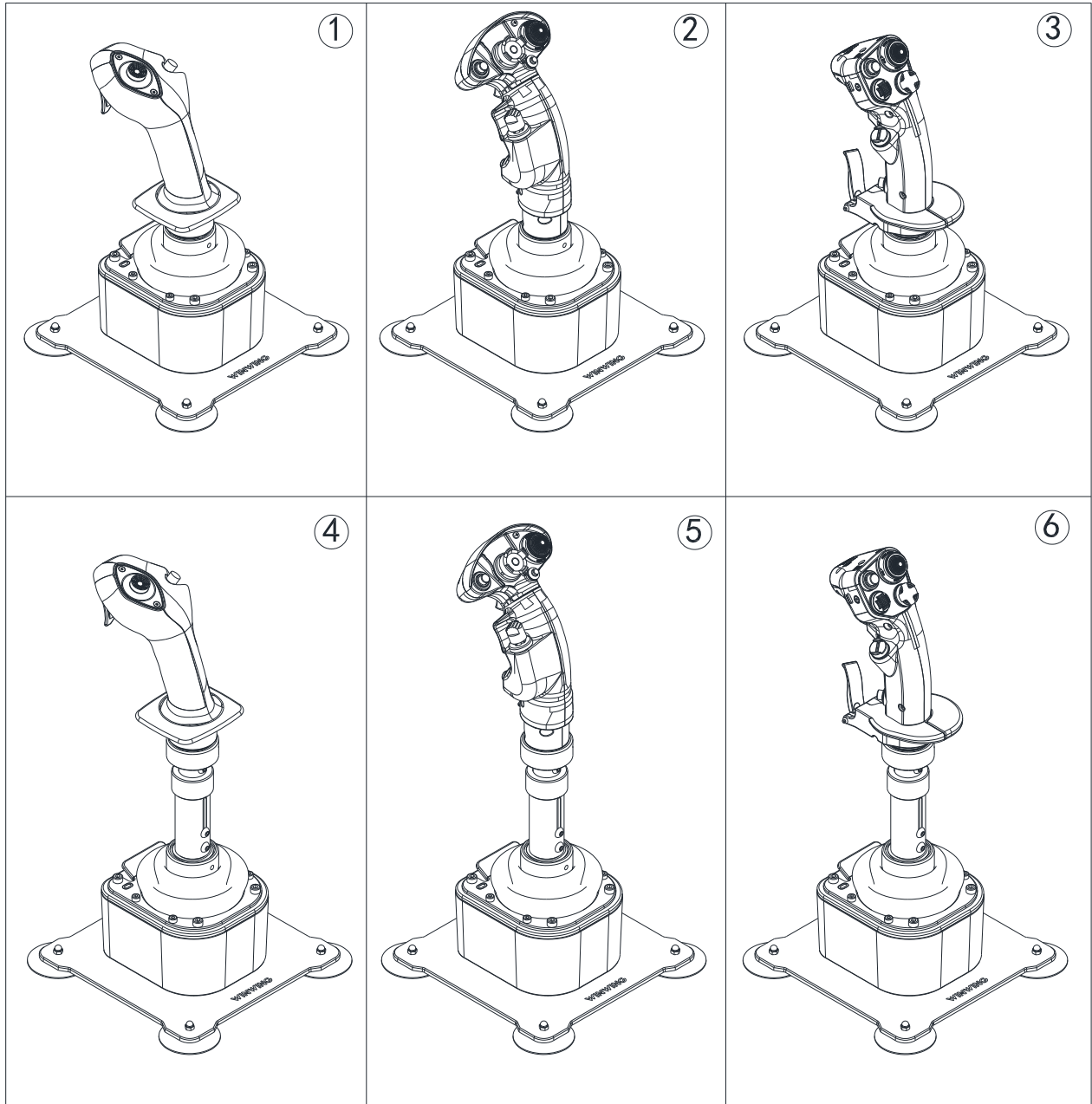

① J2-2-BAES+A320

④ J2-2-BAES+ EXTENSION1+A320

② J2-2-BAES+JGRIP-18

⑤ J2-2-BAES+ EXTENSION1+JGRIP-18

③ J2-2-BAES+JGRIP-16

⑥ J2-2-BAES+EXTENSION1+JGRIP-16

Installation method please reference 4.1.

1.3 Appearance and dimension

The length width and

height :213mm*213mm*120mm ;

Weight:1.5kg=25.35lb.

1.4 Installation dimension

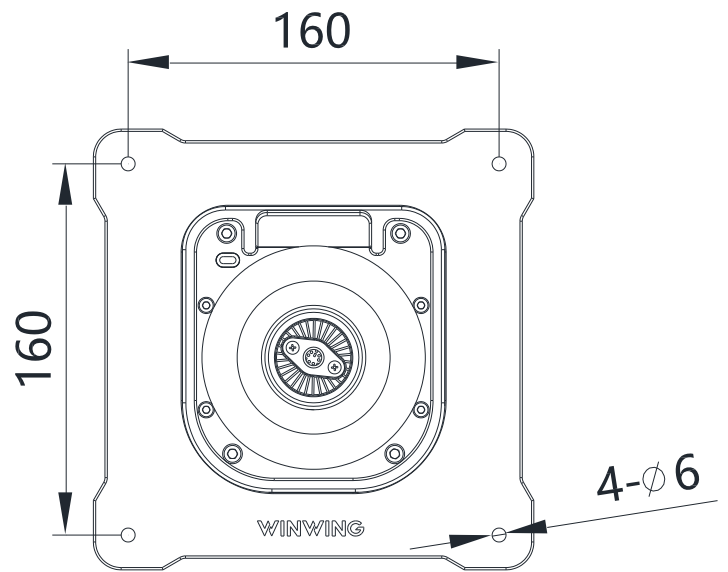
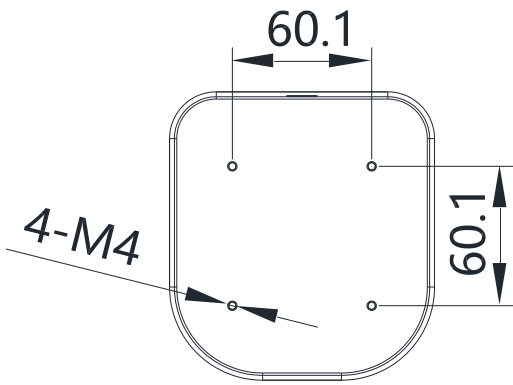
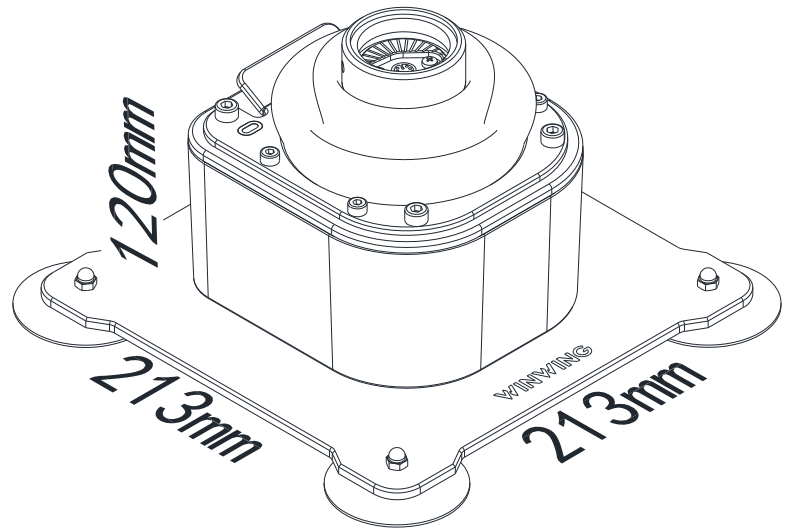

Available installation holes:











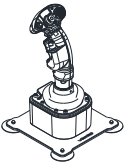



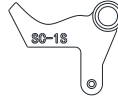
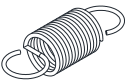

The space of 4-M4: 60.1mm*60.1mm ;

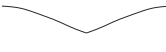
The space of 4 Ø6: 160* 160.

2 Functions

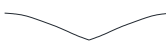
2.1 Mechanical and additional functions

1. Expandable force feedback*need to purchase EX1-J2-2(Installation method please reference:3.2.);

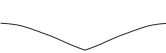
				
 拉簧0.8 Spring0.8	1.3KG  0	1.3KG  0	1.3KG  0	1.3KG  0
 拉簧1.0 Spring1.0	2.5KG  0	2.5KG  0	2.5KG  0	2.5KG  0
 拉簧1.2 Spring1.2	4.5KG  0	4.5KG  0	4.5KG  0	4.5KG  0

2. Resistance Model*Need to purchase EX 1-J2- 2(Installation method please reference:3.3.);

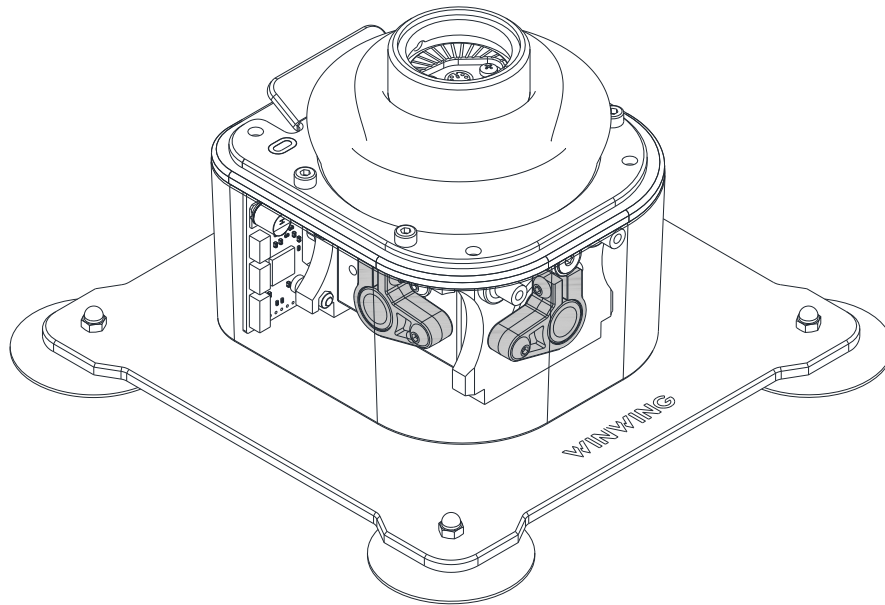

3. Sensor Model*need to purchase EX2-J2 -2(Installation method please reference3.4.).

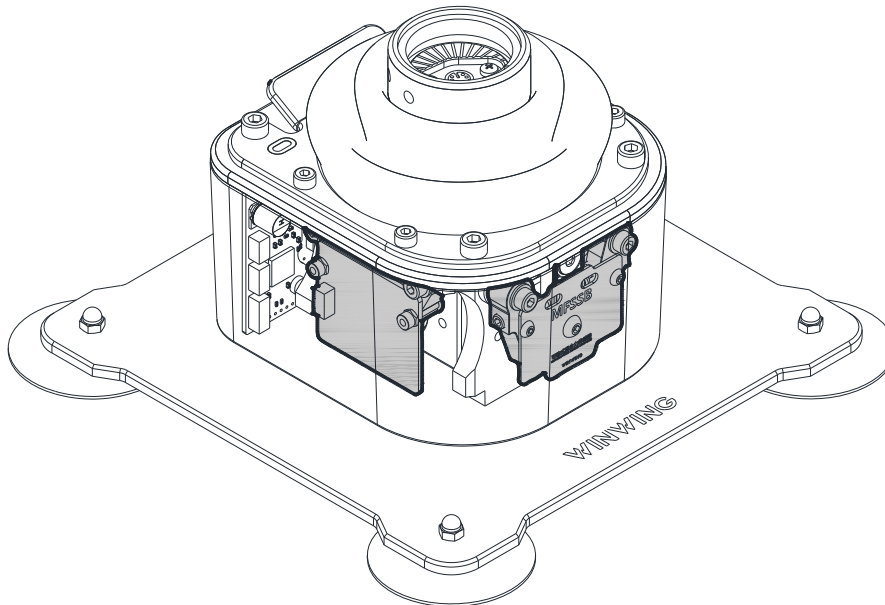

3 Parts installation

3.1 Suction cups installation

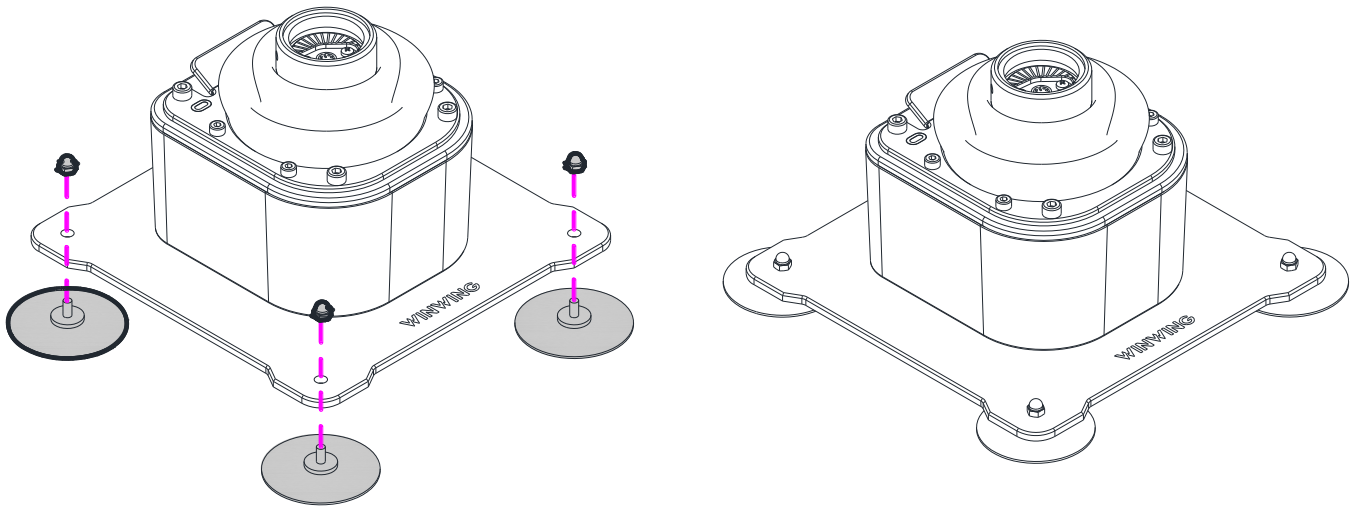

① Remove four nuts on the suction cups. Insert four screws through the plate, then tighten the nuts.

Note; Please clean the suction cups and your desk before installation.

3.2 Cams installation

Please refer to 《EX1-J2-2 User Manual 》 .

3.3 Resistance model

Please refer to 《EX1-J2-2 User Manual 》 .

3.4 Movable multiple force sensor mode

Please refer to 《EX2-J2-2 User Manual 》 .

4 Assembly methods

4.1 Devices connection

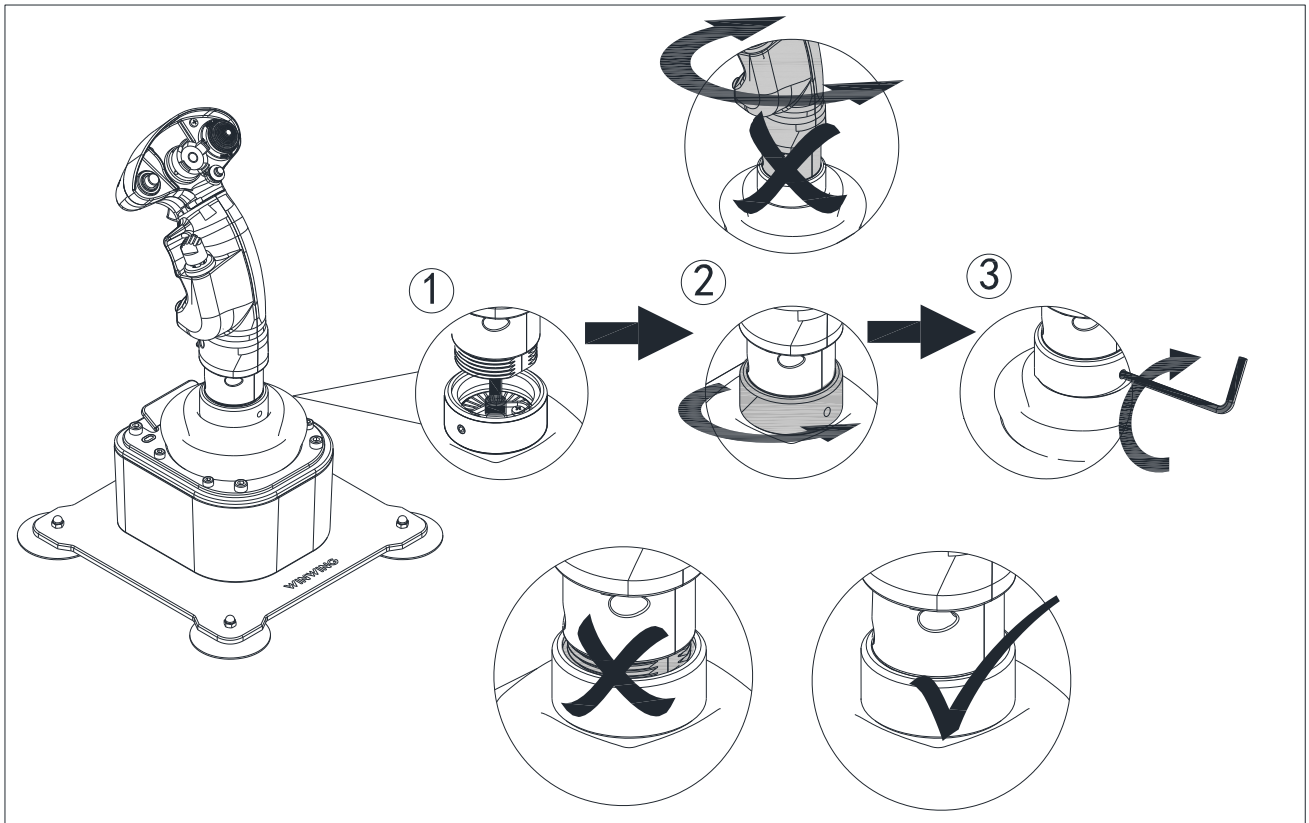

① Align and insert PS2 connector to the base.

② Twist the knurled nut anticlockwise in the figure counterclockwise, and screw holes should be roughly aligned with the flat surface of the grip when tightening (only twist the knurled cover during disassembly, otherwise the connection will be damaged)

③ Use wrench to tighten jack screw clockwise.

Note: Please reverse the steps when need to dissemble.

4.2 Mounting installation

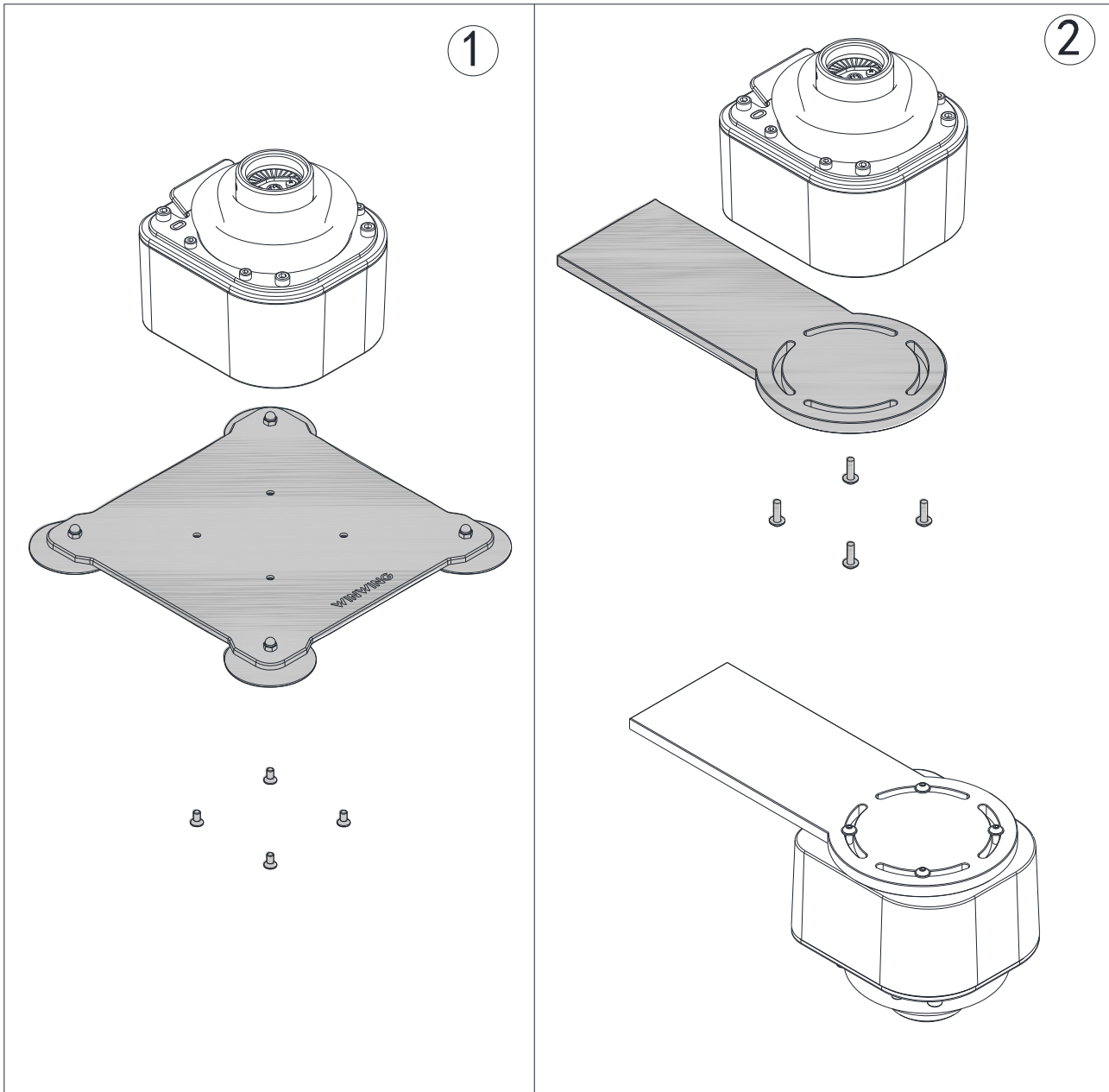

① Remove the 4 screws on the bottom, then remove the plate;

② Put the BASE on the Mounting, then install screws and spacers (prepared by yourself) from the bottom to fix it on the mounting. .

Note: Mounting, screws and spacers should be prepared by yourselves. (Pay attention to the

length of screws: 5 mm M4 screws)

* This is the final version of the manual,all update will be made online.

成都翼胜科技有限责任公司

WWW.WINWING.CN

INFO@WINWING.CN

High-tech International Enterprise Zone No.19 Building,Changshengqiao Road

1111#, Pidu District, Chengdu,China 610000